

PRODUCT NUMBER  
89892-YXXLF

WHEN NEEDED, SUFFIX LETTER "LF"  
INDICATES THE PRODUCT IS RoHS  
COMPATIBLE, SEE NOTE 5.

NUMBER OF POSITIONS PER ROW: 02 to 50

PLATING CODE  
3= 0.76µm GOLD ON CONTACT AREA  
3.81µm TIN-LEAD ON TAIL  
4= 5µm TIN-LEAD ON CONTACT AREA  
3.81µm TIN-LEAD ON TAIL  
WHEN SUFFIX "LF" IS REQUIRED, 2µm MIN MATTE  
TIN OVER 1.27 MIN Ni IS SUPPLIED INSTEAD OF SnPb.

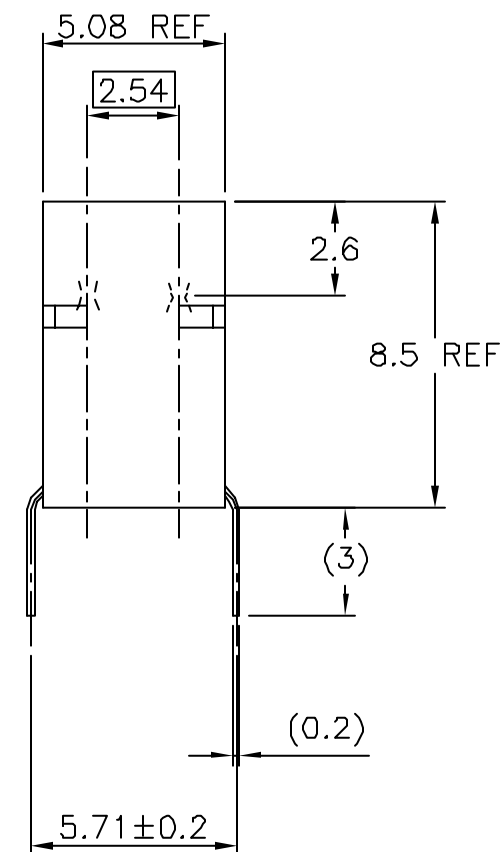
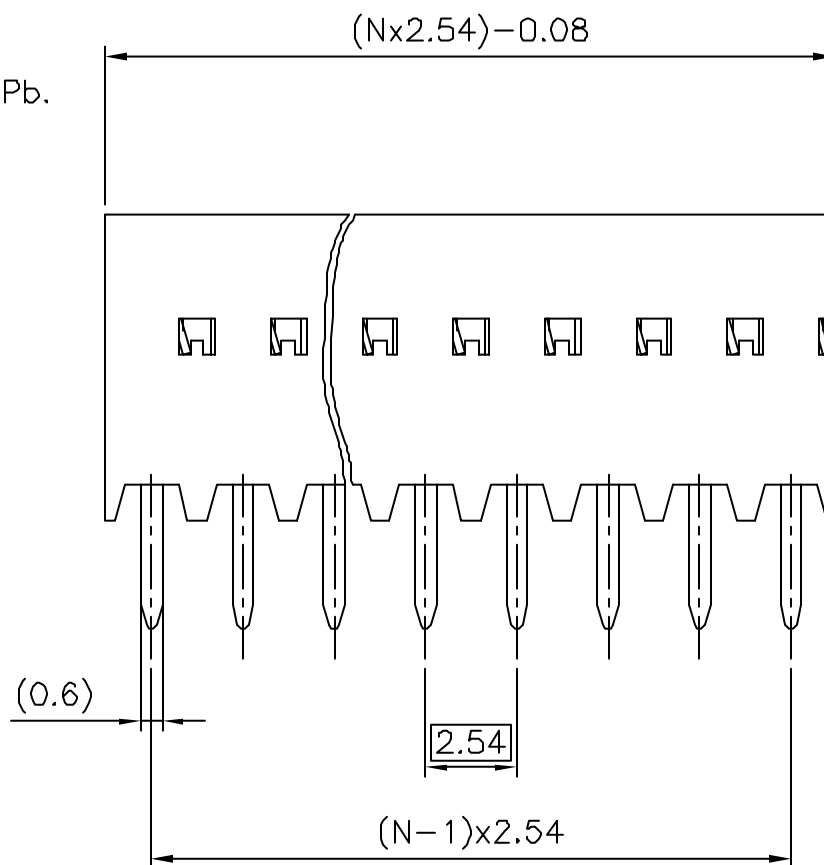
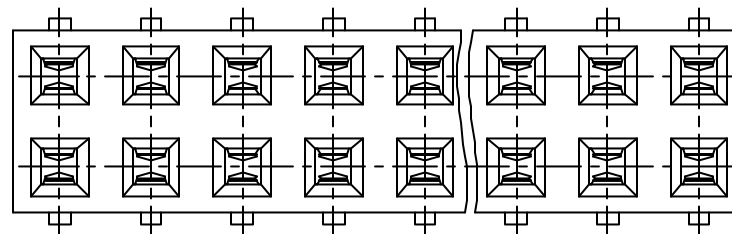

NOTES:

- 1 - HOUSING MAT'L: THERMOPLASTIC GLASS FILLED  
FLAME RETARDANT PER UL 94 V-0 COLOR: BLUE.
- 2 - TERMINAL MATERIAL : PHOSPHOR BRONZE.
- 3 - 02 UP TO 04 POSITIONS PRODUCT PACKED IN PLASTIC BOX.  
05 UP TO 50 POSITIONS PRODUCT PACKED IN TUBE.
- 4 - TO DETERMINE DIMENSIONS :  
N = NUMBER OF POSITIONS PER ROW  
EXAMPLE: 8 POS:  $(N \times 2.54) - 0.08 = 20.24$  mm
- 5 - RoHS COMPATIBLE PRODUCT SPECIFICATIONS
  - a - PLATING:
    - "LF" MEANS THE PRODUCT IS LEAD-FREE,  
2µm MINIMUM MATTE TIN OVER 1.27µm  
MINIMUM NICKEL UNDERPLATE.
  - b - MANUFACTURING PROCESS COMPATIBILITY
    - THE HOUSING WILL WITHSTAND EXPOSURE TO  
260°C ±5°C SOLDER BATH TEMPERATURE FOR  
5 SECONDS IN A WAVE SOLDER APPLICATION  
WITH A 1.6mm MIN THICK CIRCUIT BOARD.
  - c - LABELING:
    - MEETS PACKAGING SPECS AS PER GS-14-920
  - d - LEGAL STATEMENT: SEE GS-22-008

|             |          |            |          |                                       |           |            |  |                            |  |
|-------------|----------|------------|----------|---------------------------------------|-----------|------------|--|----------------------------|--|
| mat'l. code |          | surface    |          | tolerance                             |           | projection |  | product family             |  |
| SEE NOTES   |          | ISO 1302 ✓ |          | ISO 406 ISO 1101                      |           | mm         |  | DUBOX                      |  |
| ltr         | ecn no   | dr         | date     | tolerances unless otherwise specified |           | mm         |  | title                      |  |
| C           | F80638   | PNZ        | 98.10.14 | angles                                | Linear    | ±0.3       |  | BtB RECEPT.<br>VERT DR TMT |  |
| D           | F10116   | GCO        | 01.01.23 | ±2'                                   |           | scale 5:1  |  | dwg no                     |  |
| E           | F04-0347 | DLE        | 04.09.28 |                                       |           |            |  | sheet 1 of 2               |  |
| F           | F06.0204 | DLE        | 06.06.21 | dr                                    | D LEGRAND | 04.09.28   |  | size                       |  |
|             |          |            |          | enr                                   | P NIZZI   | 04.09.28   |  | 89892                      |  |
|             |          |            |          | chr                                   | D LEGRAND | 04.09.28   |  | A3                         |  |
|             |          |            |          | appd                                  | P NZ      | 04.09.28   |  | type                       |  |
|             |          |            |          |                                       |           |            |  | CUSTOMER Drawing           |  |
| sheet       | revision | F          | B        |                                       |           |            |  |                            |  |
| index       | sheet    | 1          | 2        |                                       |           |            |  |                            |  |

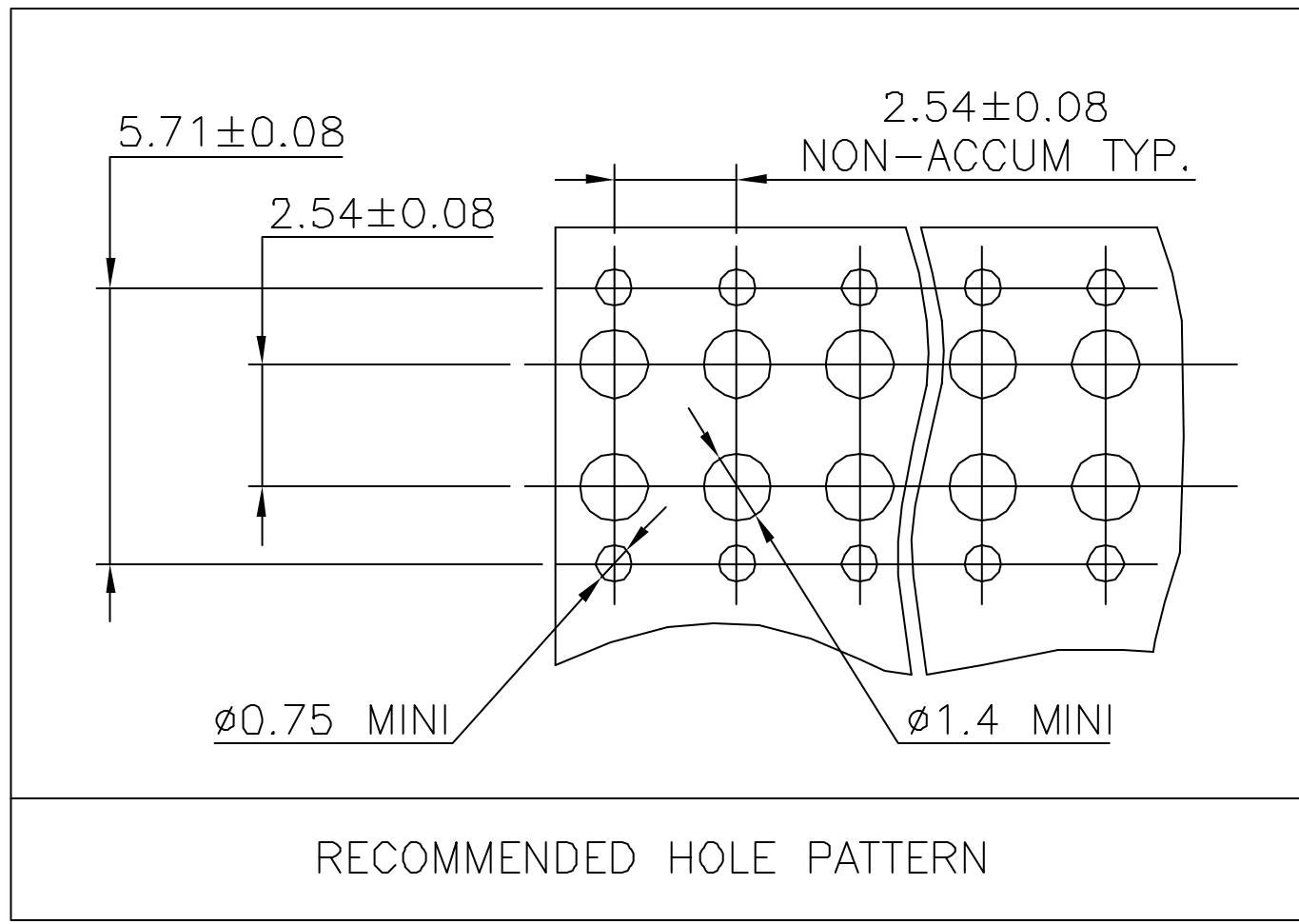

FCI  
FCIconnect.com

Copyright FCI

|                            |  |                |  |                       |  |                               |  |                |  |                            |  |              |  |         |
|----------------------------|--|----------------|--|-----------------------|--|-------------------------------|--|----------------|--|----------------------------|--|--------------|--|---------|
| mat'l. code<br>SEE SHEET 1 |  |                |  | surface<br>ISO 1302 ✓ |  | tolerance<br>ISO 406 ISO 1101 |  | projection<br> |  | product family<br>DUBOX    |  |              |  |         |
| Ltr                        |  |                |  | ecn no                |  | dr                            |  | date           |  | title                      |  |              |  |         |
| A                          |  |                |  | F04-0347              |  | DLE                           |  | 04.09.28       |  | BtB RECEPT.<br>VERT DR TMT |  |              |  |         |
| B                          |  |                |  | F06-0204              |  | DLE                           |  | 06.06.21       |  |                            |  |              |  |         |
|                            |  |                |  | angles                |  | linear                        |  | ±0.3           |  | mm                         |  |              |  |         |
|                            |  |                |  | ±2'                   |  |                               |  |                |  | scale 5:1                  |  |              |  |         |
|                            |  |                |  | dr                    |  | D LEGRAND                     |  | 04.09.28       |  | dwg no                     |  | sheet 2 of 2 |  | size    |
|                            |  |                |  | enr                   |  | P NIZZI                       |  | 04.09.28       |  | 89892                      |  | A4           |  |         |
|                            |  |                |  | chr                   |  | D LE                          |  | 04.09.28       |  |                            |  |              |  |         |
|                            |  |                |  | appd                  |  | P NZ                          |  | 04.09.28       |  | type                       |  | CUSTOMER     |  | Drawing |
| sheet index                |  | revision sheet |  |                       |  |                               |  |                |  |                            |  |              |  |         |